

WIRE NUMBER LABELS FOR USE ON CABLE ASSYS									
WIRE NO	CONDUCTOR COLOR	SAE SIZE	LENGTH TOT IN	CABLE ASSY	TP	REMARKS	TP	REMARKS	LABLES REQ'D
1883A	BLK	10	5	I/O-A	SA12	USE INSUL	AAD	USE INSUL	2
1883B	BLK	10	5	I/O-B	SA12	USE INSUL	AAD	USE INSUL	2
1883C	BLK	10	5	I/O-C	SA12	USE INSUL	AD	USE INSUL	2
1883D	BLK	10	5	I/O-D	SA12	USE INSUL	AE	USE INSUL	2
1883E	BLK	10	5	I/O-E	SA12	USE INSUL	AP	USE INSUL	2
1884A	RED	10	5	I/O-A	SA12	USE INSUL	AAD	USE INSUL	2
1884B	RED	10	5	I/O-B	SA12	USE INSUL	AAD	USE INSUL	2
1884C	RED	10	5	I/O-C	SA12	USE INSUL	AD	USE INSUL	2
1884D	RED	10	5	I/O-D	SA12	USE INSUL	AE	USE INSUL	2
1884E	RED	10	5	I/O-E	SA12	USE INSUL	AP	USE INSUL	2

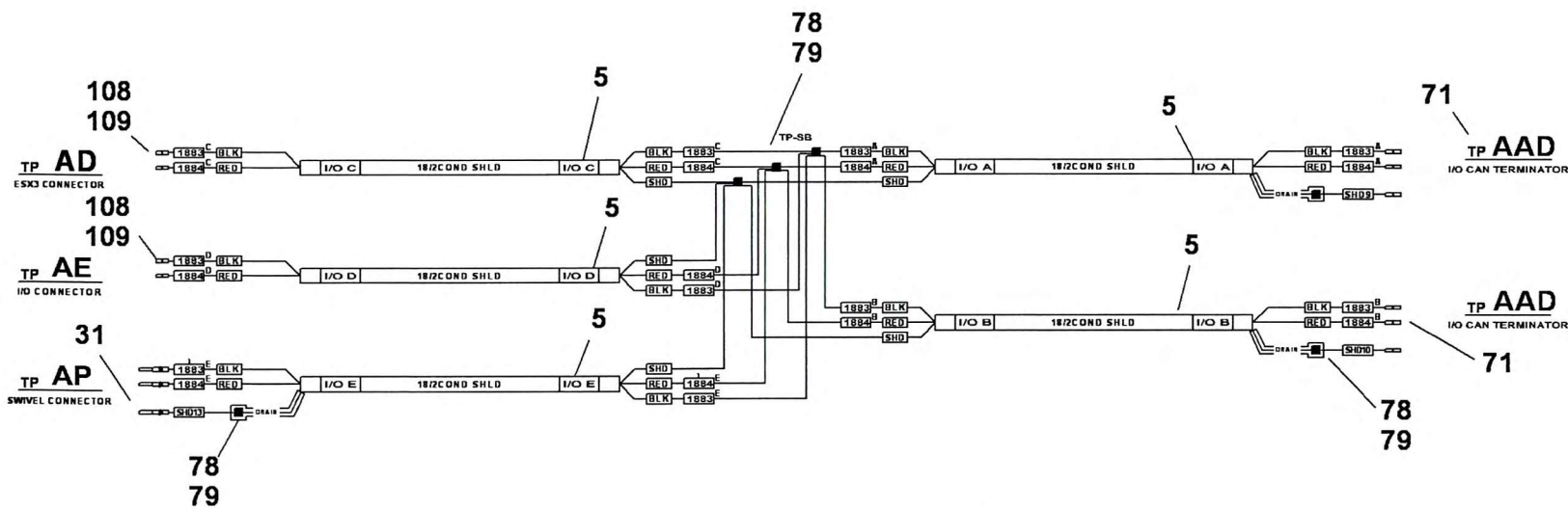

**CABLE DETAIL I/O CAN A,B,C,D,E**  
CONTROL MODULE PROPRIETARY CABLE

(SHEET 8 OF 8)

Page 641

80035809

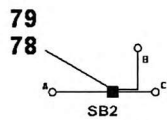

DETAIL 7

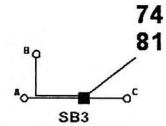

DETAIL 1091

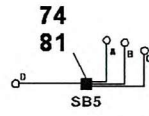

DETAIL 1189

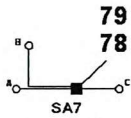

DETAIL 10

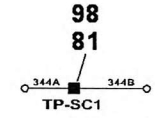

DETAIL 344

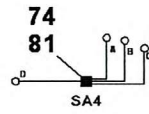

DETAIL 1186

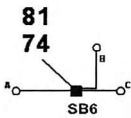

DETAIL 13

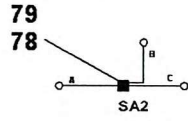

DETAIL 440

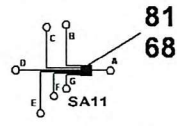

DETAIL 1409

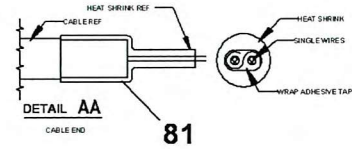

DETAIL AA  
CABLE END

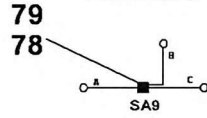

DETAIL 25

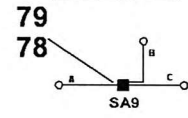

DETAIL 553

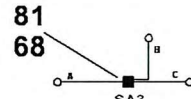

DETAIL 1539

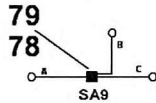

DETAIL 32

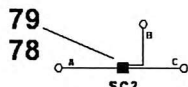

DETAIL 713

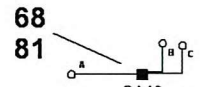

DETAIL 1568

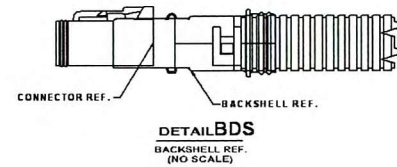

DETAIL BDS  
BACKSHELL REF.  
(NO SCALE)

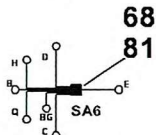

DETAIL 51

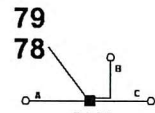

DETAIL 1074

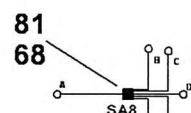

DETAIL 1818

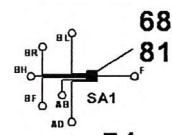

DETAIL 51

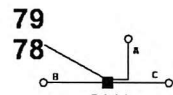

DETAIL 1791

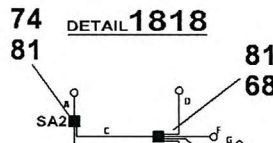

DETAIL 1827

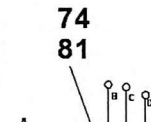

DETAIL 2156

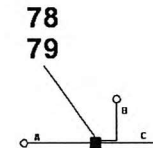

DETAIL 2070



WIRE NUMBER LABELS FOR USE ON CABLE ASSYS									
WIRE NO	CONDUCTOR COLOR	SAE SIZE	LENGTH TOT IN	CABLE ASSY	TP	REMARKS	TP	REMARKS	LABELS REQ'D
1175	WHIT	10	5	AP1	BT	USE INSUL	AP	USE INSUL	2
1176	RED	10	5	AP1	BT	USE INSUL	AP	USE INSUL	2
1177	BLK	10	5	AP1	BT	USE INSUL	AP	USE INSUL	2
1289C	RED	10	5	J1939C	SA7	USE INSUL	BT	USE INSUL	2
1289D	RED	10	5	J1939D	AF	USE INSUL	SA7	USE INSUL	2
1289E	RED	10	5	J1939E	AP	USE INSUL	SA7	USE INSUL	2
1290C	BLK	10	5	J1939C	SA7	USE INSUL	BT	USE INSUL	2
1290D	BLK	10	5	J1939D	AF	USE INSUL	SA7	USE INSUL	2
1290E	BLK	10	5	J1939E	AP	USE INSUL	SA7	USE INSUL	2
1728A	RED	10	5	ESX 1	AP	USE INSUL	AAE	USE INSUL	2
1728B	RED	10	5	ESX 2	AD	USE INSUL	AAE	USE INSUL	2
1729A	BLK	10	5	ESX 1	AP	USE INSUL	AAE	USE INSUL	2
1729B	BLK	10	5	ESX 2	AD	USE INSUL	AAE	USE INSUL	2
1929	RED	10	5	RS232	AD	USE INSUL	AP	USE INSUL	2
1930	BLK	10	5	RS232	AD	USE INSUL	AP	USE INSUL	2
1813	RED	10	5	DRF	AE	USE INSUL	AK	USE INSUL	2
1814	BLK	10	5	DRF	AE	USE INSUL	AK	USE INSUL	2
1815	RED	10	5	DRR	AE	USE INSUL	BQ	USE INSUL	2
1816	BLK	10	5	DRR	AE	USE INSUL	BQ	USE INSUL	2

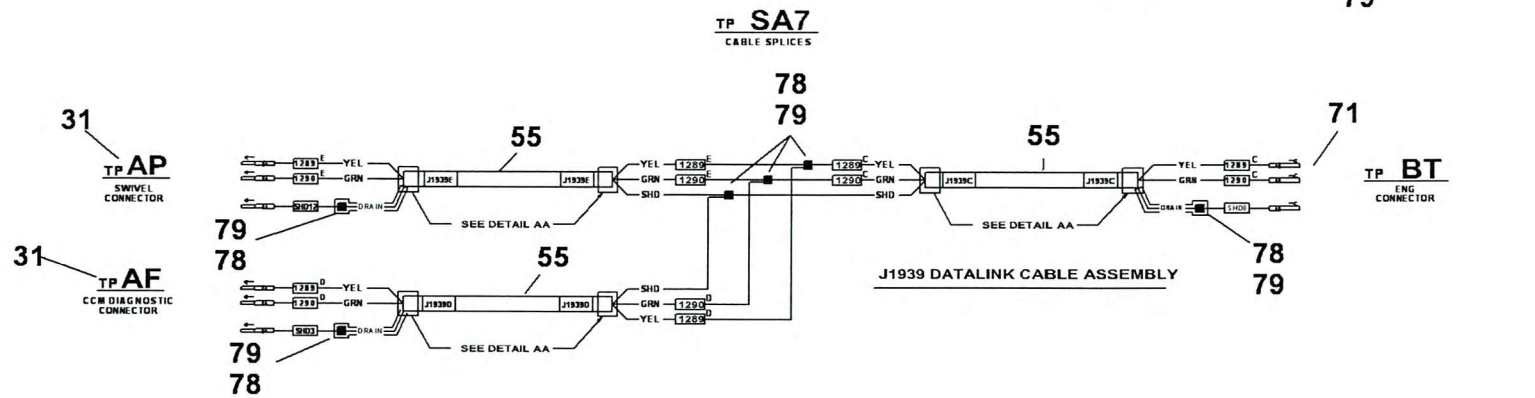
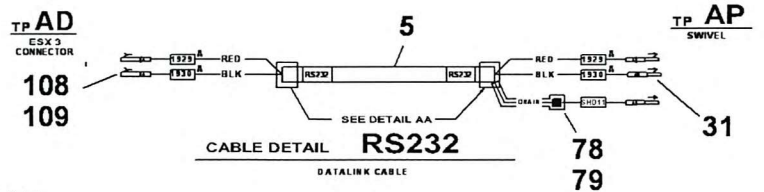
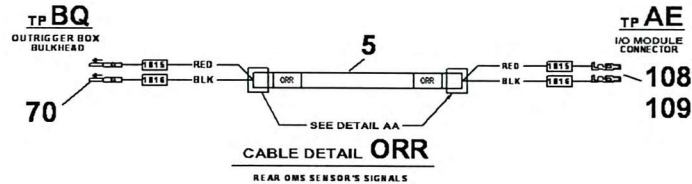
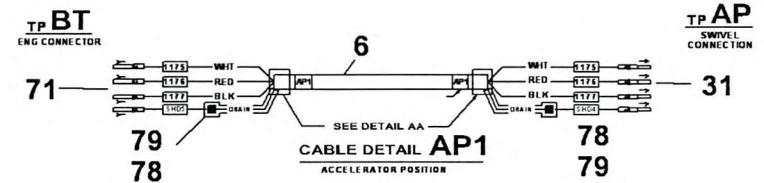
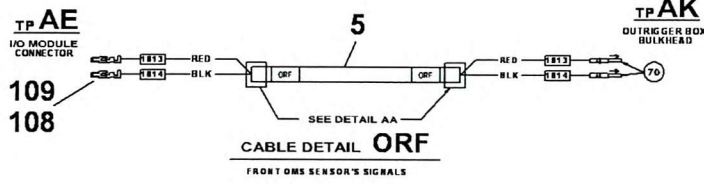
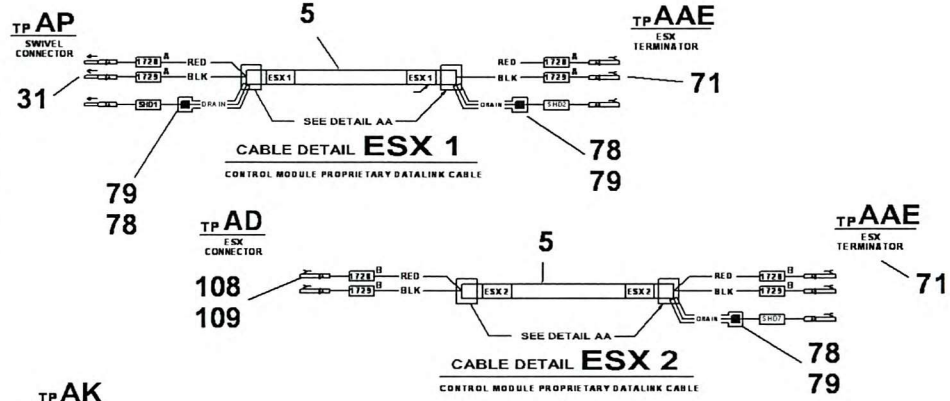

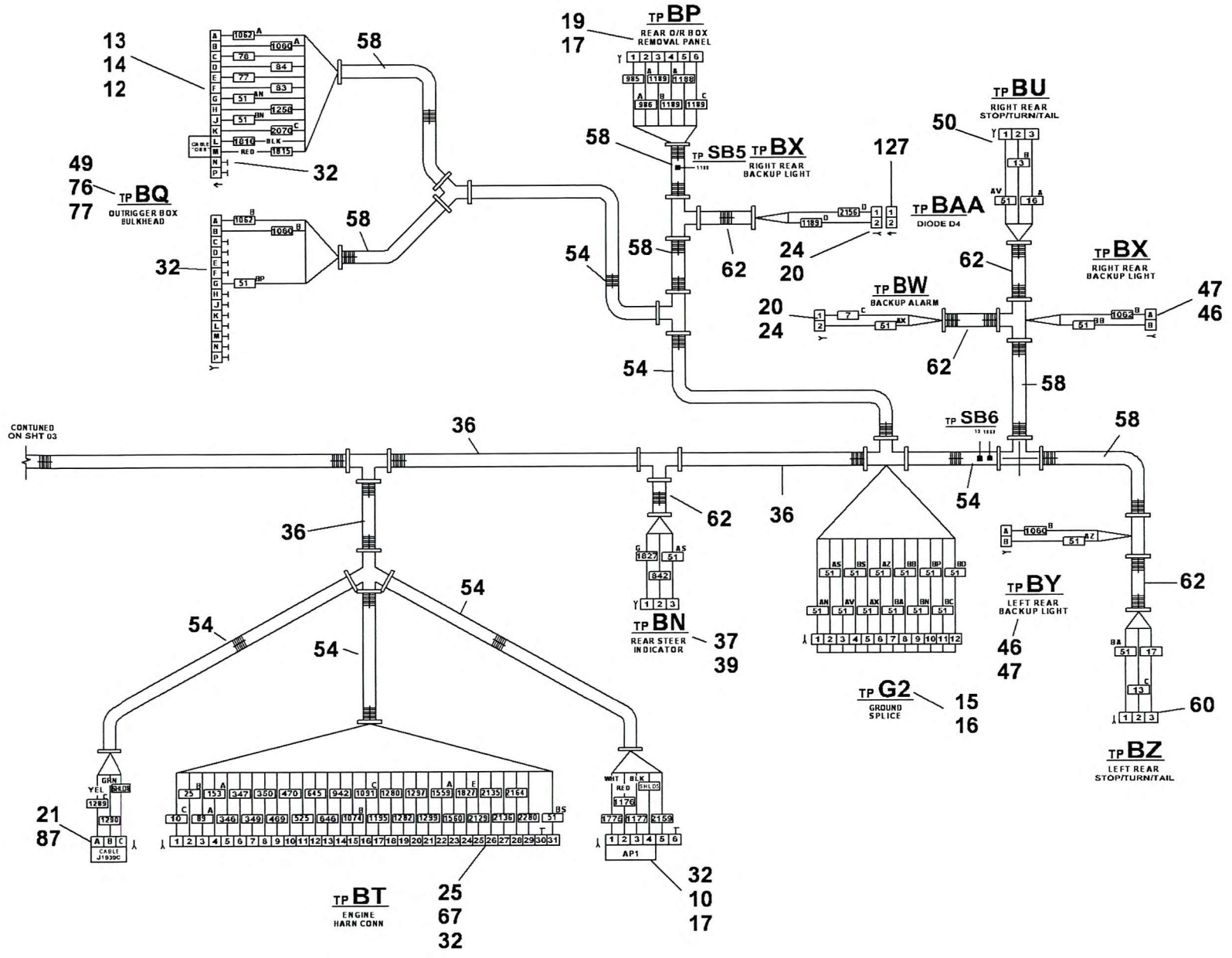

(SHEET 4 OF 8)

Page 645

80035809

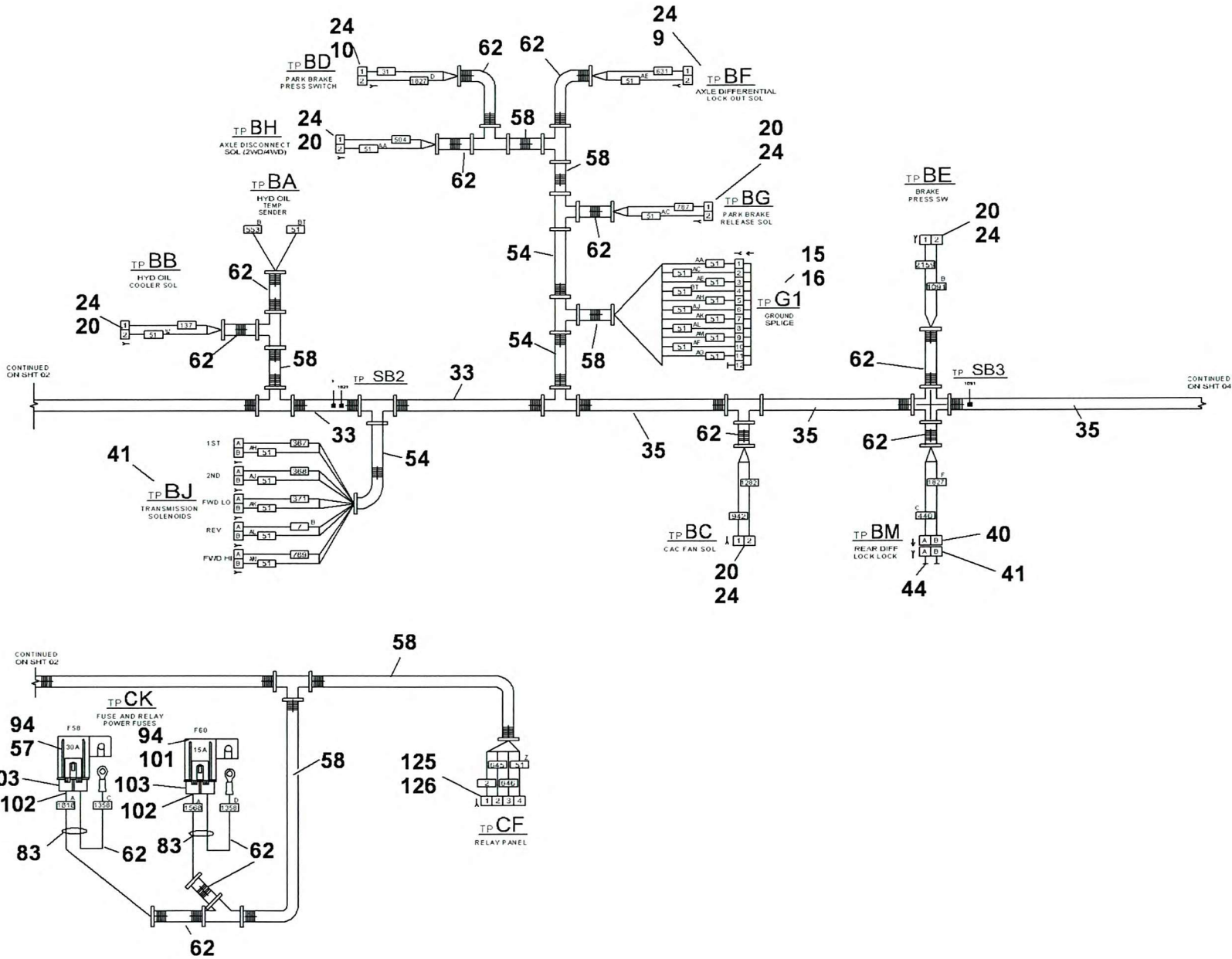

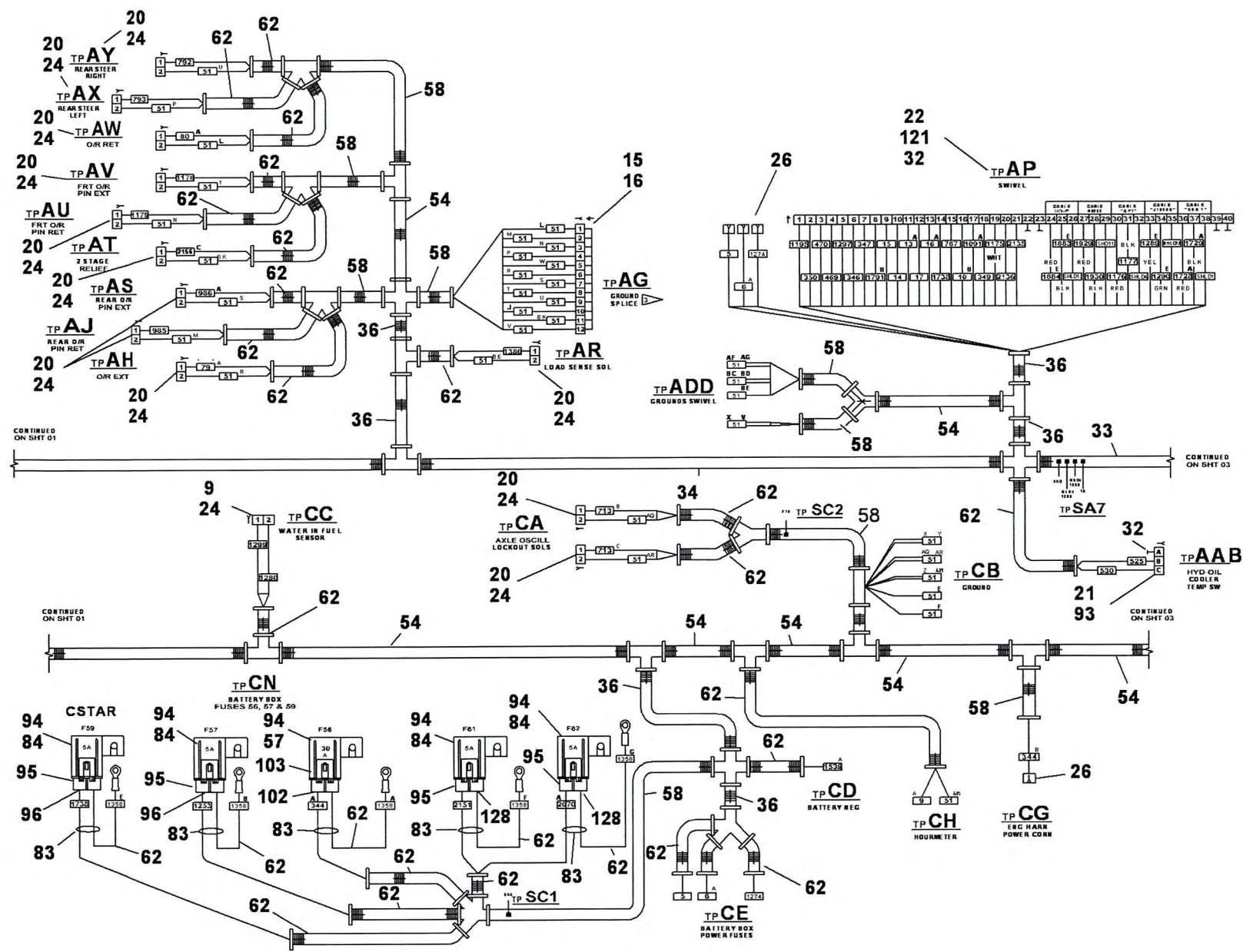

(SHEET 2 OF 8)

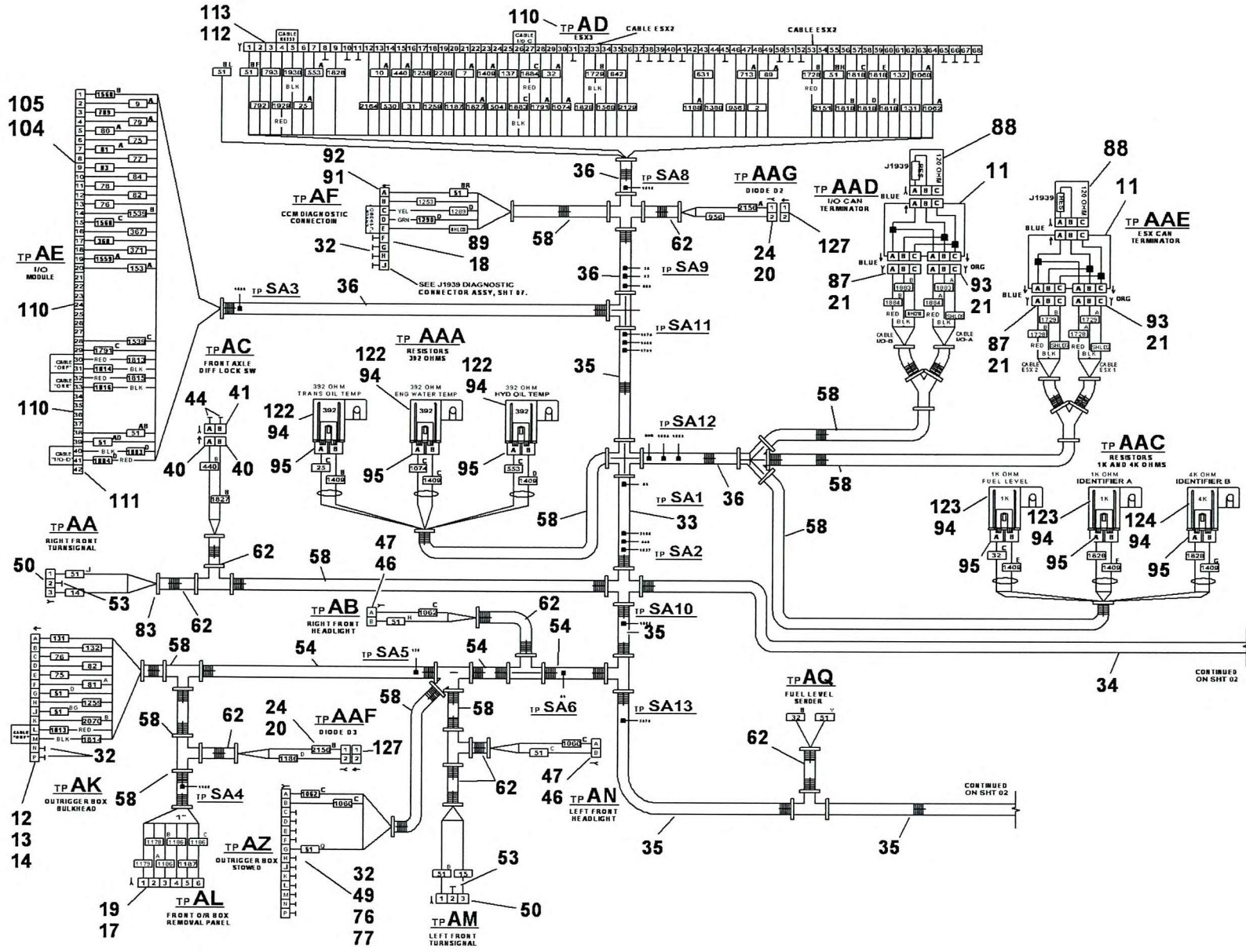

CONTINUED ON SHT 02

CONTINUED ON SHT 02